

FALCON XTREME 270

SET-UP & CARE INSTRUCTIONS

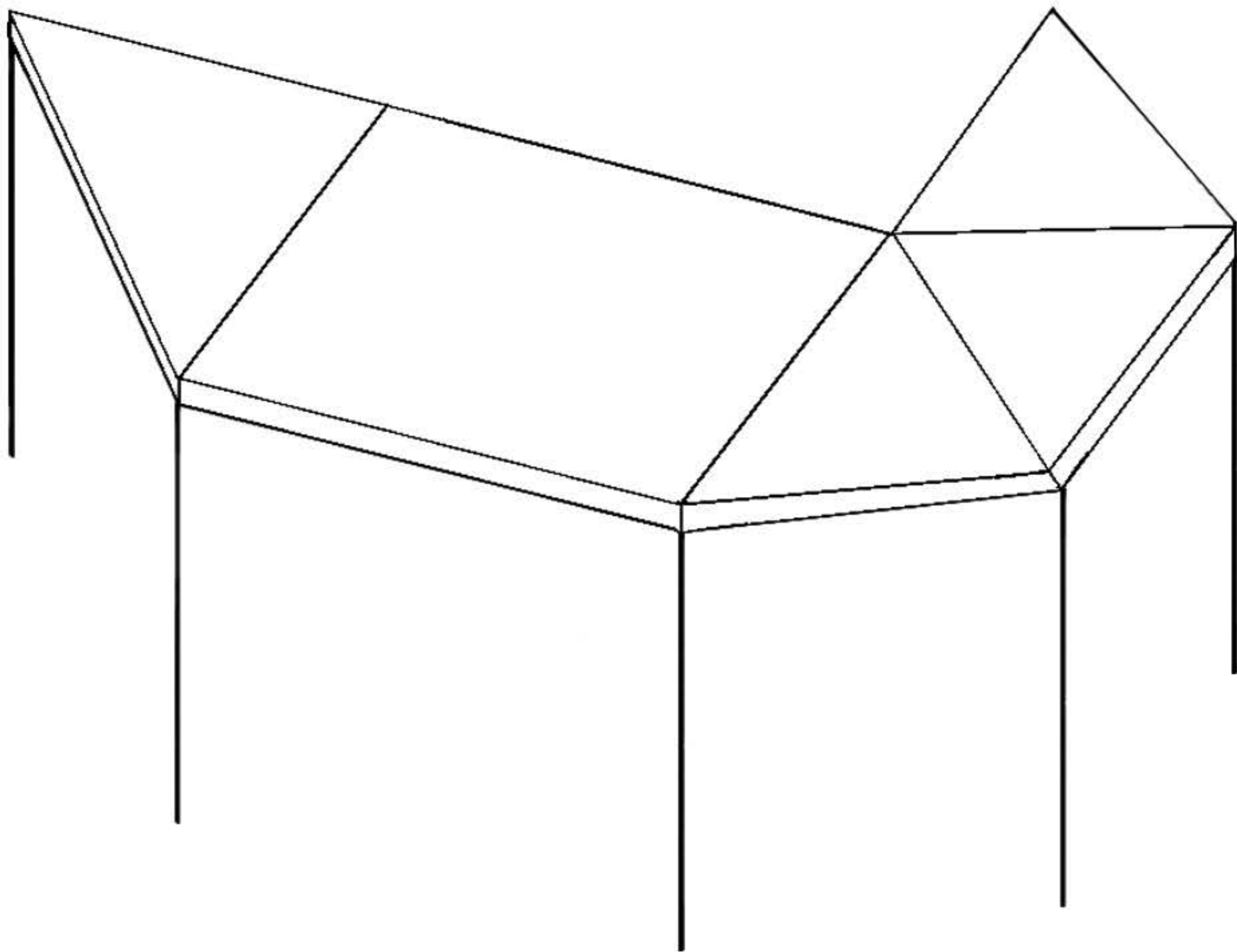

CONGRATULATIONS ON THE PURCHASE OF YOUR NEW FALCON XTREME AWNING FROM THE TEAM AT 23 ZERO. PLEASE READ INSTRUCTIONS CAREFULLY PRIOR TO FIRST USE. IF YOU REQUIRE FURTHER ASSISTANCE PLEASE CONTACT 23 ZERO PH 9547 4691
EMAIL: info@23zero.com.au

GET TO KNOW YOUR AWNING

We recommend you check all parts are included prior to first use.

CONTENTS

1 x Falcon XTREME	6 x 25mm M8 mounting bolts and nuts	2 x Cam Buckle Tension Straps
3 x Mounting Brackets	Twist-lock leg poles	Twist Lock legs in carry bag
6 x 'U' Bolts with nuts and washers	Pegs and guy ropes in bag	

MOUNTING BRACKET TO ROOF RACK

1

23 ZERO FALCON XTREME mounting brackets are suited to many roof rack designs. However with the increasing number of new designs / models available from reputable brands some additional hardware may need to be obtained for correct secure fitment.

NOTE: We highly recommend discussing specific load capacities and mounting options with a specialist roof rack retailer or installer.

ATTACHING BRACKETS TO AWNING

23 ZERO recommends using a qualified or experienced fitter to mount the FALCON XTREME to your vehicle. Fasteners and all fixing connections including hinges should be checked and inspected regularly to ensure the awning is fixed securely to your vehicle roof rack at all times

! PROLONGED TRAVELING ON UNEVEN CORRUGATED ROADS WILL REQUIRE MORE FREQUENT INSPECTIONS.

NOTE: 23 ZERO takes no responsibility or liability for fitment of the FALCON 270° awning to your specific vehicle or trailer.

2

1. Place the awning on protected clean surface with rear facing up.
2. At each end of the awning measure and mark the PVC in line with the two channel grooves at approx 500mm back from end of awning (Ideally no more than 600mm) See Fig. 1 & 2



Fig. 1



Fig. 2



Fig. 3

Note: The third bracket can be fitted near the centre of the awning or as required to suit.

Note: The position of the two channel grooves can be felt by pressing down and running your finger along the PVC.

3. Using a sharp blade score a 5mm cross at the centre of the channel groove at your measurement markings. See fig. 3
4. Totally un-zip awning cover.
5. Starting at one end carefully pull back each side of the PVC so channel grooves are exposed. See fig. 4



Fig. 4



Fig. 5



Fig. 6



Fig. 7

6. Insert two 25mm M8 bolts in each channel groove and slide across in line with your marked score in the PVC. See fig. 5
7. Place scored PVC directly above bolt and push down firmly until bolt pierces PVC and is exposed. See Fig. 6
8. Place bracket holes in line with bolts and fasten using M8 nut and washer. See Fig. 7
9. Repeat for all three bracket

FALCON XTREME SET-UP

NOTE: AWNING WILL FREE STAND FOR SET-UP AND PACK DOWN

3 REMOVE COVER
Unzip cover ① and fold it over the awning body ②.

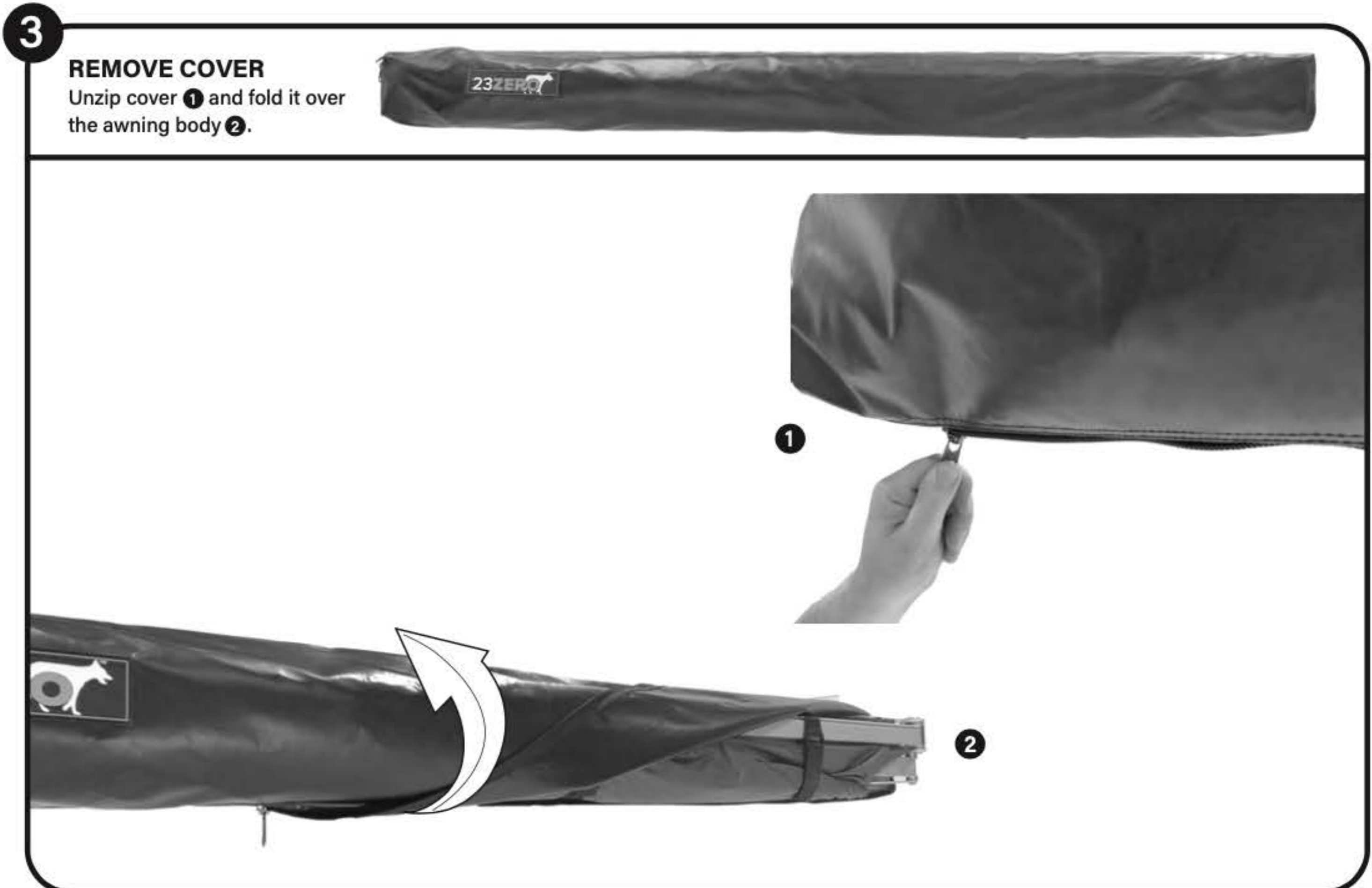

4 DEPLOY AWNING
Release the three Velcro straps ① and allow canvas to drape ②.

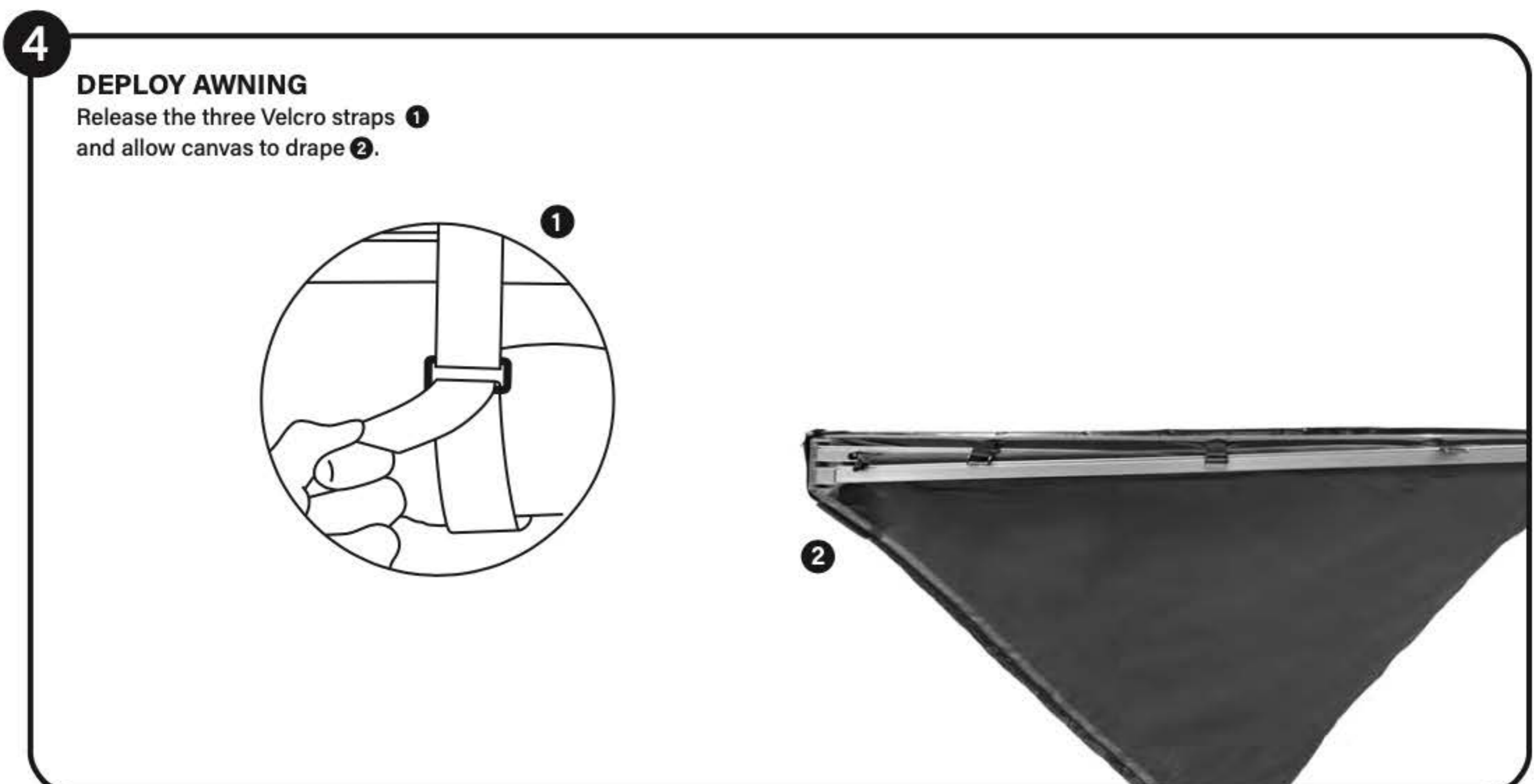

SET-UP

NOTE: IT IS ADVISABLE TO TENSION THE RIGHT REAR ARM TO DESIRED POSITION PRIOR TO LEFT FORWARD ARM

5

DEPLOY AWNING Cont.

- 1 To release and set up awning swing right hinged arms 90 degrees from vehicle
- 2 Fully swing out left hinged arms and attach too roof rack 4 with supplied cam buckle tension strap
- 3 Fully swing right arm toward rear of vehicle and attach roof rack 4 with other supplied cam buckle strap.

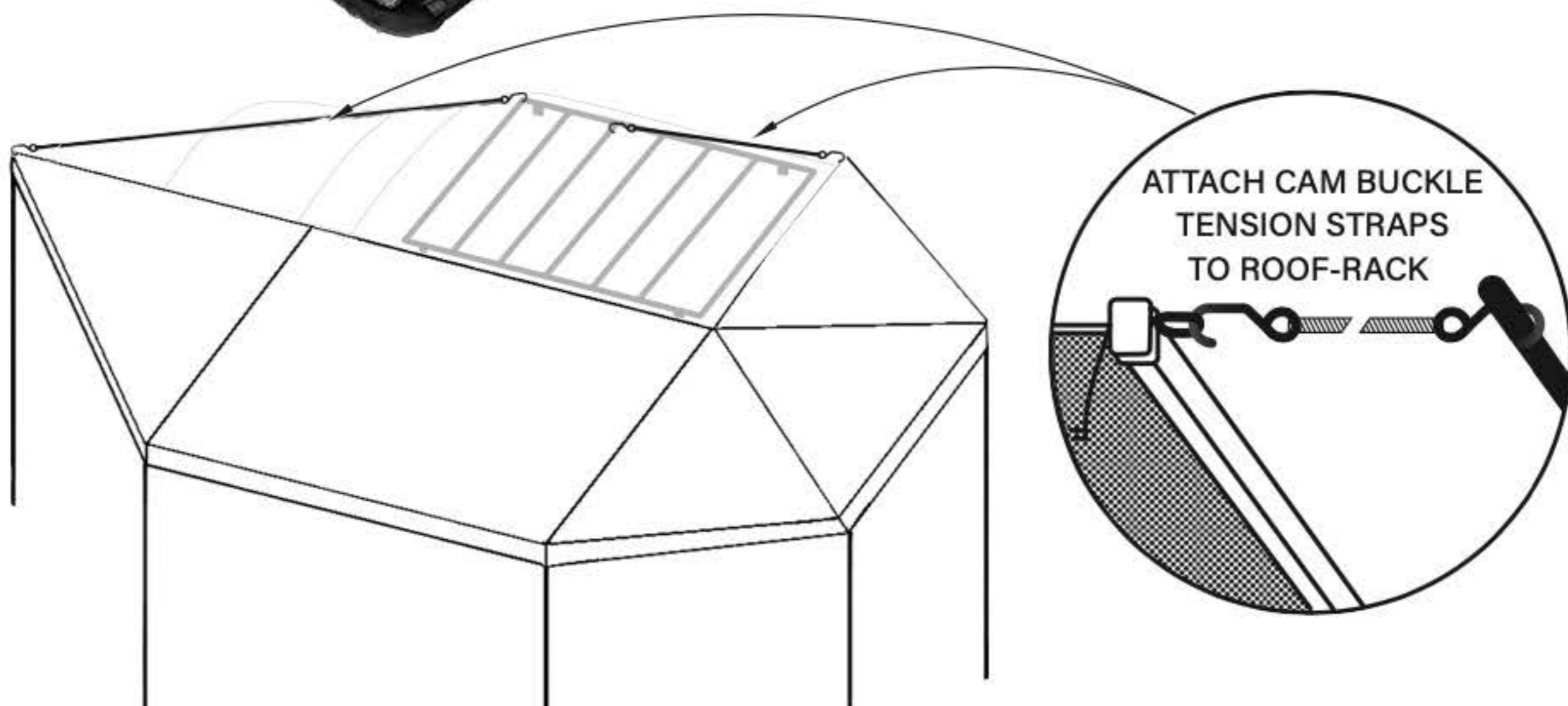

SET-UP

6

POLE SET UP

- 1 Undo Velcro tabs supporting integrated leg poles to awning rafter.
- 2 Adjust pole height accordingly with twist lock function.
- 3 Attach remaining individual support legs to other rafters by inserting spigot end into located holes at end of rafter.

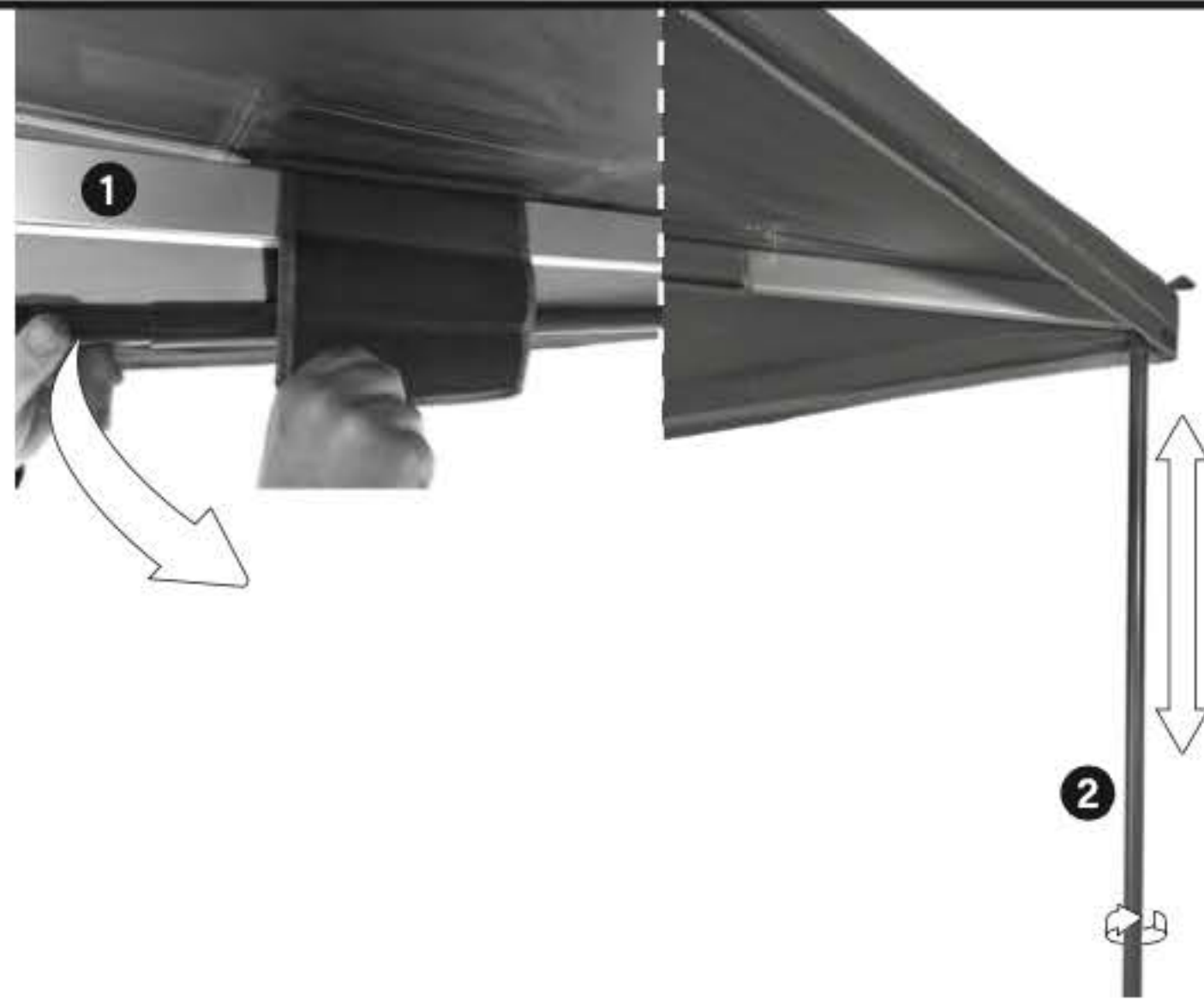

! ENSURE ALL GUY ROPES ARE ATTACHED AND ANCHORED

! IF ATTACHING WALLS TO THE FALCON XTREME AWNING, RAFTERS MUST BE SUPPORTED BY LEG POLES PROVIDED

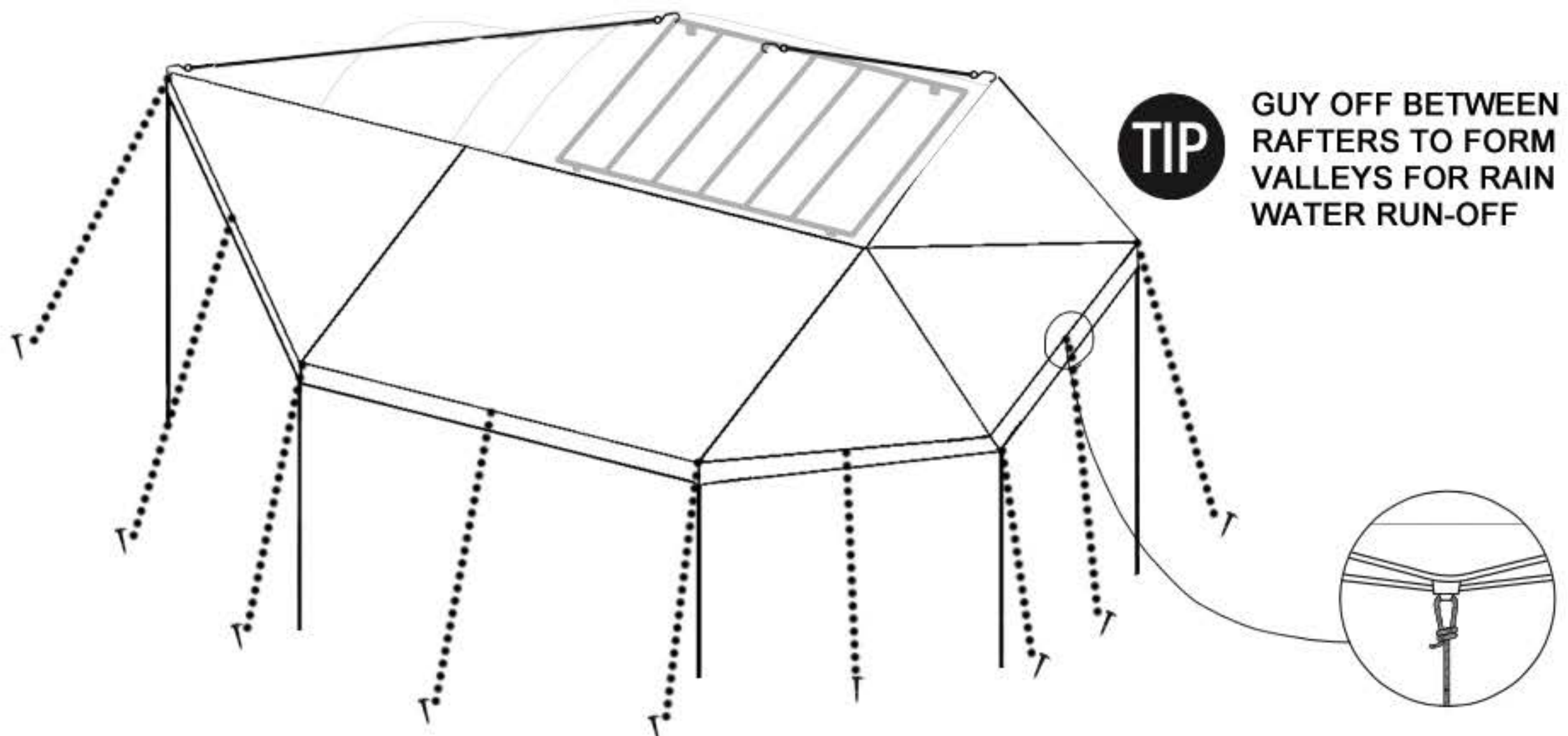

TIP GUY OFF BETWEEN RAFTERS TO FORM VALLEYS FOR RAIN WATER RUN-OFF

PACK DOWN

7

PACK DOWN

Remove pegs & guy ropes.

Fold away legs and secure with Velcro rafter tabs - remaining legs can be stowed into pole bag.

Release front and rear cam buckle tension straps attached to awning.

1 Fold right hand side rafters at 90° from awning body.

2 Fold left side rafters against awning body ensuring top rafters sit on top of bottom rafters.

3 Fold right side rafters against left side rafters ensuring top rafters sit on top of bottom rafters neatly.

4 Adjust hanging canvas so it drapes in a triangular shape

Tightly roll canvas and secure with attached straps.

5 Fold over PVC transit cover and zip up - Run zip sliders towards the rear of the awning.



1 Fold RHS 90° to this position



3 Complete the RHS fold

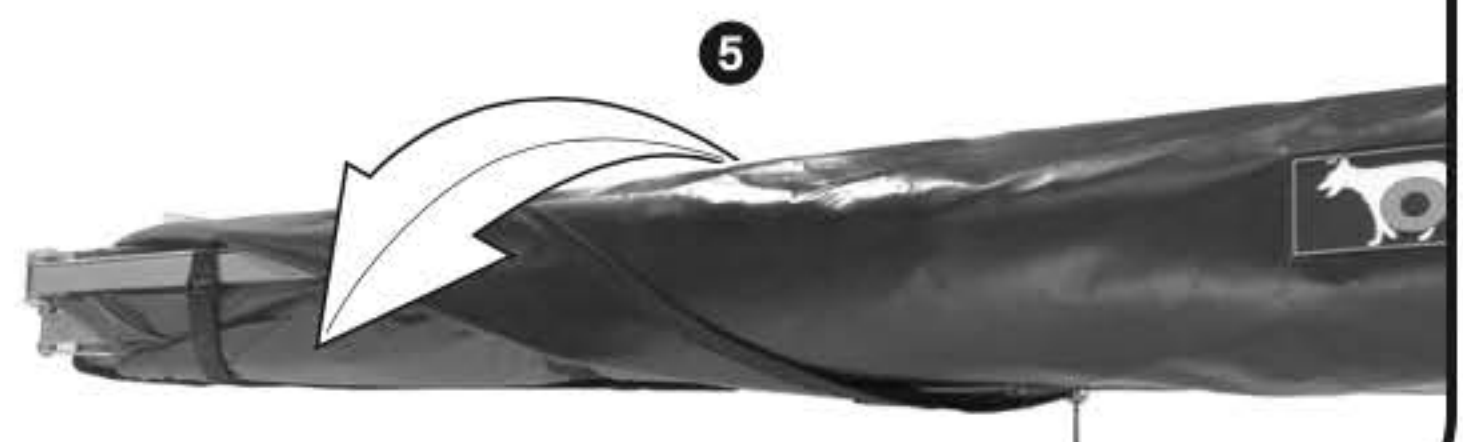

LED LIGHTING

8

The Falcon Xtreme is outfitted with three diffused LED lights strategically placed along designated rafter arms. These lights offer three modes and five dimmable settings, which include options for white, white/amber, and amber illuminations

- The LED lighting cables are conveniently stored in a pouch along the rear arm of the Falcon Xtreme



- Insert the male fitting into the LED light port as shown, ensuring that you use the extended cable end for the LED light port farthest away, and then proceed to connect it to a standard USB outlet.



CARE AND SAFETY

CLEANING

Clean with luke warm water and soft bristle brush.
Do not use soaps and or detergents.
Do not expose to petro chemicals.

STORAGE

Certain situations may require the Falcon Xtreme to be packed down wet. It is essential that at the earliest opportunity the Falcon awning is unpacked and allowed to dry fully. Though we use the best polyurethane proofing available, prolonged exposure to moisture causes hydrolysis which can affect the integrity of the proofing. Storing awning wet in warm conditions is likely to cause mildew growth which will stain canvas and lead to premature breakdown.

SET-UP WITH A COMMON SENSE APPROACH

"The Falcon Xtreme is intended to be a self-supporting awning. We strongly advise taking a proactive and sensible approach to reduce the potential for harm or property damage caused by unexpected strong wind gusts. Utilizing the integrated poles and securing guy ropes for added stability while using the 23 Zero Falcon Xtreme will enhance safety and prolong the products lifespan."

WATERPROOFNESS

23 ZERO use a selection of refined raw materials and treatments in its design and development processes including long lasting polyurethane coatings and high frequency seam sealing.

With multiple layer seams and addition of zips wind driven rain may cause small amounts of water ingress at times. Rubbing a softened candle wax stick over the affected area will help reduce any water ingress.



TO AVOID PERSONAL INJURY AND OR PROPERTY DAMAGE, 23 ZERO STRONGLY ADVISES AGAINST SETTING UP THE FALCON XTREME DURING PERIODS OF HIGH WINDS OR INCLEMENT STORMY WEATHER. PLEASE NOTE THAT DAMAGE RESULTING FROM ADVERSE WEATHER CONDITIONS OR IMPROPER USAGE MAY NOT BE ELIGIBLE FOR COVERAGE UNDER THE MANUFACTURER'S WARRANTY



SAFETY WARNINGS

KEEP ALL FLAME AND HEAT SOURCES AWAY FROM AWNING FABRIC.

UNDER NO CIRCUMSTANCES SHOULD ANY NAKED FLAME SOURCES BE USED NEAR THE AWNING.

KEEP CAMP FIRES AT LEAST 20 METERS AWAY FROM AWNING.

WATCH FOR AIRBORNE BURNING EMBERS THAT MAY COME IN CONTACT WITH THE AWNING

KEEP A FIRE EXTINGUISHER OR WATER BUCKET NEARBY.

KEEP EXITS CLEAR

VEHICLE EXHAUST FUMES CAN BE DEADLY - DO NOT RUN VEHICLE ENGINE WHILST WALLS ARE ATTACHED TO THE AWNING.

WATCH FOR GUY ROPES AND PEGS AS THEY CAN BE A TRIP HAZARD

ENSURE CHILDREN ARE SUPERVISED AROUND THE AWNING AT ALL TIMES.