

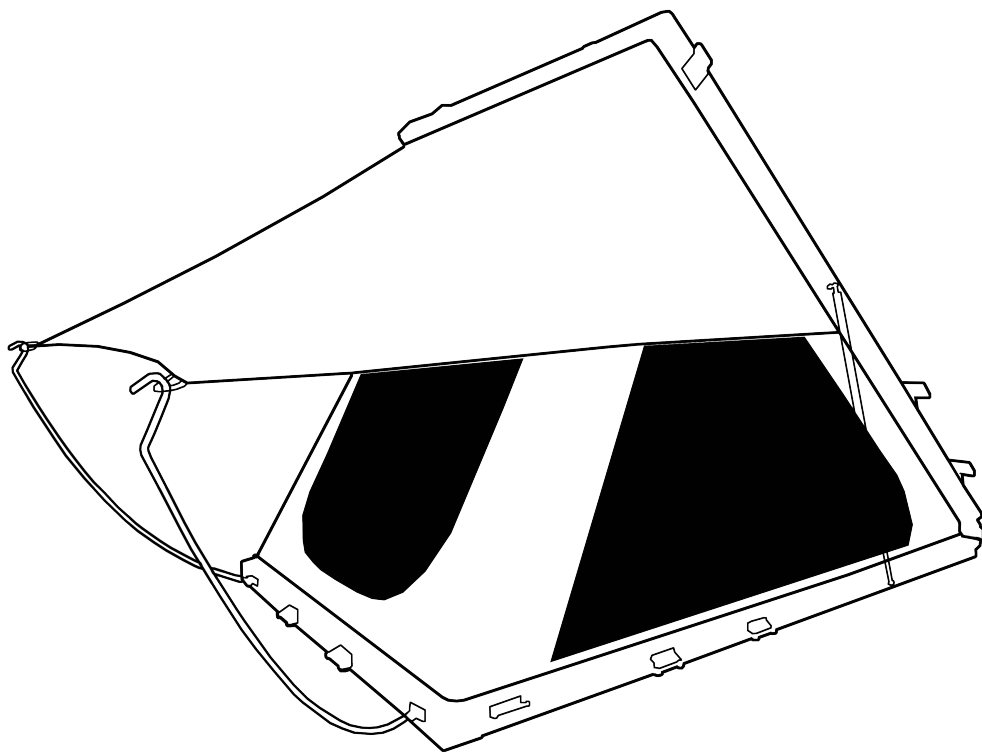

SABER SUPER FLY

USER MANUAL



Thank you for purchasing a 23 ZERO Roof Top Tent

Congratulations on the purchase of 23ZERO's Saber Super Fly Hardshell Roof Top Tent. We strive to provide you with the ultimate camping experience. The Saber Super Fly Tent mounts directly to a roof rack or aftermarket roof bars. It opens and is fully setup in seconds. As well as our innovative LST fabric, this hardshell tent is made with durable materials and high-quality fabrics that provide excellent water and wind protection.

The Saber Super Fly tent can be mounted directly onto a supportive platform-style roof rack or an accommodating roof bar system (refer to installation requirements for details).

Most components are pre-assembled, except for ladder brackets, fly rods, roof brackets and roof bars.

Note: During set up and first use, some aluminium swarf may be present inside the roof top tent. We make every possible attempt to expel all aluminium swarf, however, with vibrations caused by logistics some residual may dislodge and reappear. It is advised to remove and clean these during first set up.

PLEASE READ ALL INSTRUCTIONS PRIOR TO INSTALLING

IMPORTANT

Installation Requirements

For correct installation

- The saber super fly must be mounted to a supportive platform-style roof rack or roof bar system
- The tent is designed for attachment to
 - A full-length platform style rack
 - A flat-style rack
 - A minimum of four crossbars (evenly spaced)
- For proper stability, the tent rails must be supported by planks or no fewer than four evenly spread cross members along the rack (refer to page 5).

Before installing your 23Zero Roof Top Tent please ensure you are aware and understand the following:

- Your vehicle's maximum roof load rating.
- Your roof rack's maximum load rating including off-road capacity.

The maximum amount of weight you can safely add to a vehicle's roof / cargo area differs according to make and type of vehicle including aftermarket additions such as roof racks / bars. Note: Roof rack off-road limits are immensely different to normal road use load ratings. If in doubt, please contact your vehicle manufacturer and roof rack manufacturer / supplier for specified loading capacity of your vehicle and roof rack.

Not all factory roof racks or aftermarket roof bars can safely accommodate roof top tent models. The responsibility of fitting this roof top tent to rated roof racks or roof bars lays with the purchaser.

CONTENTS

Safety & Warnings	3
Hardware & Accessories	4
Fitting to roof rack	5
Installation process	6,7
Roof bars	8
Ladder adjustment	9
Opening & Set up	10
Closing & Storage	10
Warranty	11
Mounting rail dimensions	12

Safety & Warnings

Improper installation or use of the Saber Super Fly roof top tent may result in serious injury or death. Follow these installation instructions carefully to ensure proper installation to vehicle and safe use of the roof top tent.

Note: Alterations and / or inclusions such as roof racks and roof top tents applied to the vehicle roof may affect vehicle handling and characteristics.

The manufacturer (23ZERO) disclaims all responsibility in case of accidents and / or damage due to installation of a roof top tent to an underrated roof rack, improper use, improper maintenance or checking the tightness of the brackets regarding the installation of the roof rack system.

Inspections: Roof top tents have many moving parts, so maintenance checks are always advised. During trips regularly check that all nuts and bolts attaching the roof top tent to the vehicle as well as hinges and locks are tight and in good repair.

Ladder: For your safety and protection, ensure correct placement and angle of ladder. Recommended ladder placement is a 4:1 ratio or approx. 75°.

Ladder height may need to be adjusted depending on vehicle height, see Ladder Adjustment-*page 9*.

DO NOT CLIMB ON LADDER UNTIL CORRECT ANGLE IS ACHIEVED

23Zero - The wholesaler / manufacturer shall not be liable for special, indirect incidental or consequential damages.



SAFETY WARNING



KEEP ALL FLAME AND HEAT SOURCES AWAY FROM THE TENT MATERIALS.

UNDER NO CIRCUMSTANCE SHOULD ANY NAKED FLAME SOURCES OR HEATING DEVICES

BE USED INSIDE OR NEAR THE TENT.

KEEP CAMP FIRES WELL AWAY FROM TENT.

KEEP A LOOK OUT FOR ANY AIRBORNE BURNING EMBERS THAT MAY COME INTO CONTACT WITH THE TENT.

KEEP A FIRE EXTINGUISHER OR WATER BUCKET NEARBY.

DO NOT SMOKE WITHIN THE TENT.

DO NOT OPERATE ANY DEVICE WHICH BURNS FUEL INSIDE OF THE TENT.

KEEP EXIT CLEAR.

Hardware & Accessories

The Saber Super Fly Hardshell roof top tent includes a mounting kit with everything required to mount the roof top tent to most roof racks.

 <p>x8 M8 55mm bolts, nuts and washers</p>	 <p>x8 M8 16mm bolts, nuts and washers</p>
<p>x4 Mounting Saddles</p> 	 <p>x8 M8 20mm bolts, nuts and washers</p>
 <p>8 x Saber SF end bar caps</p>	 <p>4 x Saber SF Roof attachments</p>
 <p>4x Roof bar attachments</p>	<p>Tools</p> 

Note: Some platform style roof racks have platforms which are wider than the supplied mounting plate. 23ZERO have wider mounting plates available for this scenario.

Please visit www.23zero.com.au.

Fitting to roof rack

Recommended and efficient installation of the Saber Super Fly

The Saber Super Fly is designed to be attached directly to a full-length platform-style rack, flat rack or minimum 4 roof bars. For proper stability, the tent rails should be supported by planks or multiple cross members along the rack.



ENSURE TENT IS CLOSED AND OVER THE CENTRE LATCHES ARE FULLY SECURED DURING FITMENT

Installation Instructions

Ensure Proper Closure.

Before starting the installation, ensure that the tent is fully closed and the **center latches are securely fastened**.

Securing the Tent to the Roof Rack.

1. Prepare the components:
 - a. Used the provided hardware:
 - i. **8 x M8-55mm bolts**
 - ii. **8 x M8 Nylock nuts and washers**
 - iii. **4 x mounting saddles**
2. Positioning the tent:
 - a. With the assistance of at least **four individuals**, carefully lift the roof top tent onto the vehicle's roof rack.
 - b. Insert the **8 M8-55mm hex head bolts** into the bottom mounting rails.
 - c. Arrange the bolts so that there are **two set of bolts in each corner of the tent**.
3. Aligning the tent:
 - a. Lift or tilt the tent slightly to allow the inner bolts to slide over and align with the **roof bars or cross members**.
 - b. Confirm that the tent is positioned to open unobstructed in the desired orientation.
 - c. It is recommended to align the rear of the tent flush with the back of the vehicle to achieve the correct ladder angle.
4. Securing the tent:
 - a. Place a mounting saddle under each roof bar, aligning it with the bolts.
 - b. Add washers and hand-tighten the **Nylock nuts**. Repeat this process for all four corners.
 - c. Check the position of the tent and make any necessary adjustments.
5. Final tightening:
 - a. Using a **13mm spanner**, securely tighten all nuts. Ensure that the bolts are positioned horizontally and not skewed to avoid stainless steel galling.
 - b. Insert the **end caps** into the mounting rails. Use a soft hammer, if necessary, to gently tap them into place.

Important notes

- **Avoid using powered devices to torque the nuts. Always use the 13mm spanner provided or a similar hand tool.**
- **Periodic inspections;** Roof top tents have various moving parts, so regular maintenance checks are advisable. During trips, routinely inspect and ensure that all the above fixings are torqued and in good condition.
- **Refer to following page (7) for illustration demonstrating the install process.**

Installation Instructions

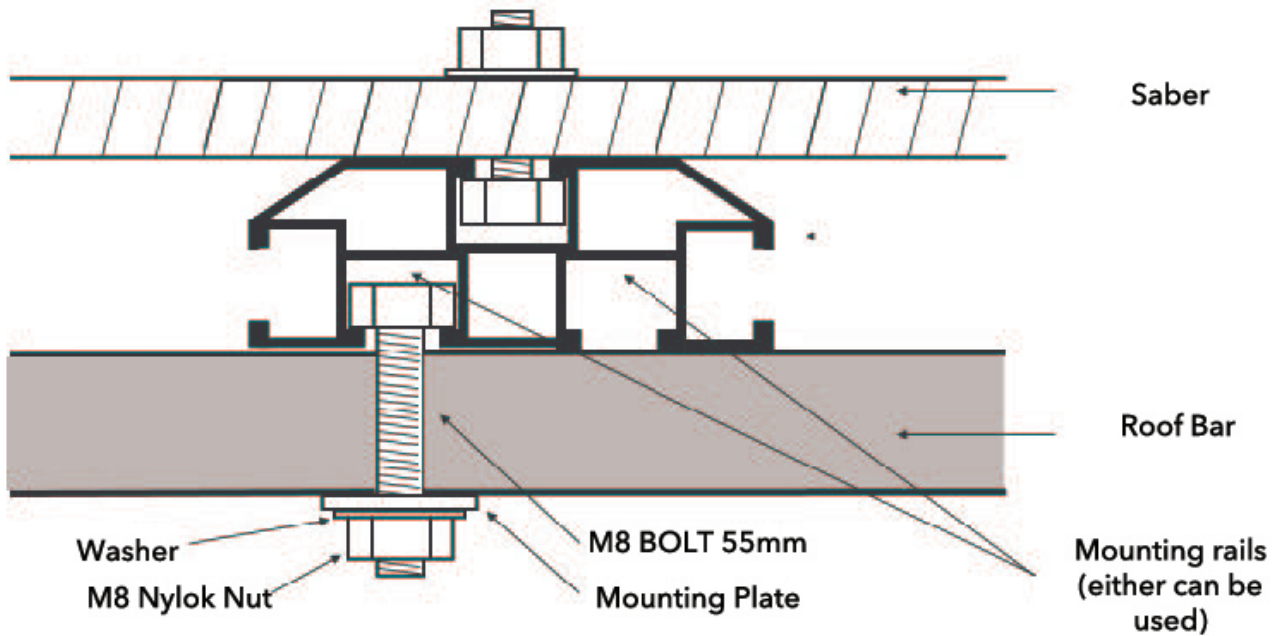

Roof bars

The Saber Super Fly roof top tent has 2 x optional roof bars which require installation. The roof bars can only be mounted via the existing 4 factory-fitted T-bolts sections located towards the rear of the tent.

Installation steps:

1. **Initial assembly**
 - a. Fix the roof bars loosely to the provided brackets
2. **Positioning**
 - a. Place the bars over the pre-fixed T-slot brackets on either side of the tent.
 - b. Use the provided M8 20mm bolts, washers and nylock nuts
3. **Alignment and securing**
 - a. Once the roof bars are centered, torque both the roof bar and the bar brackets securely
 - b. Check for security and stability
4. **Final touch**
 - a. Fit rubber caps to the ends of the bar profiles

See below illustration for reference.

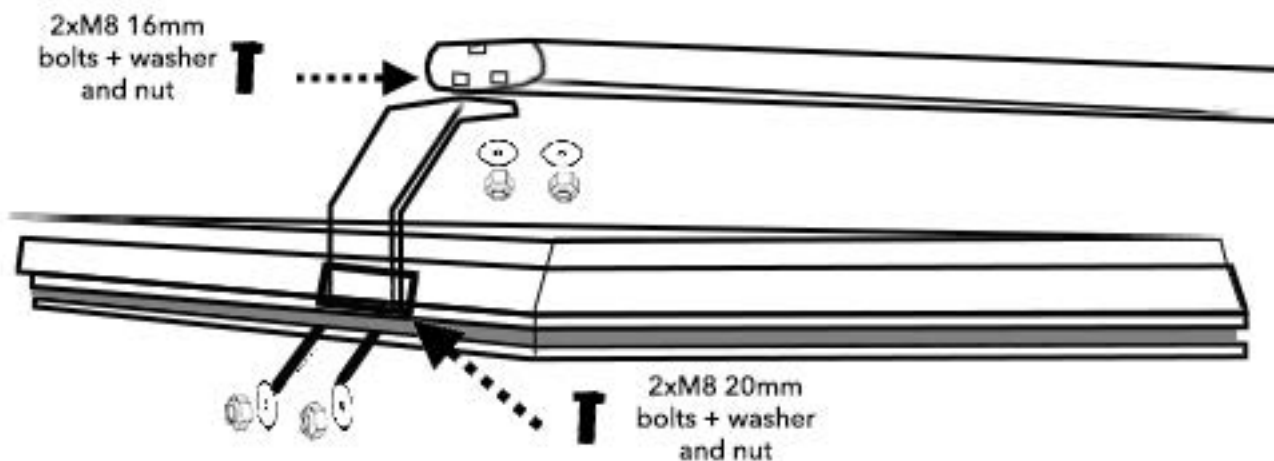

Note: The roof bars supplied with the Saber Super Fly roof top tent are not designed to carry significant loads. A maximum of 10kg can be carried on top of the Saber Super Fly providing this weight is spread evenly amongst the two bars. Load weights greater than 20kg will void any warranty.

When adding additional weight to the top of the Saber consideration must be given to the overall weight rating capacity of your vehicle's roof and roof rack.

Please ensure you are aware and understand the following:

- Your vehicle's maximum roof load rating.
- Your roof rack's maximum load rating including off-road capacity.

The maximum amount of weight you can safely add to a vehicle's roof / cargo area differs according to make and type of vehicle including aftermarket additions such as roof racks / bars.

Important: Before each trip please check that all roof bar and bracket fixings are tight and in good order before adding load.

Ladder adjustment

For your safety and protection, ensure correct placement and angle of ladder. See diagrams below. Recommended ladder placement is a 4:1 ratio or approx. 70° to 75°.

NOTE: Under no circumstances should anyone be inside the roof top tent if the ladder is not locked and secured at the correct angle.



The ladder may need to be adjusted to achieve the correct angle depending on the height of your setup. If shortening is required, the adjustment must be done from the top.

Ensure the ladder is fully extended and all rungs are locked in place. Press the first set of locking buttons (second rung from the top) and allow the ladder to compress until a gap of approx. 85mm is achieved between rung 1 & 2.

Note: The ladder will only lock in the downward position.

Swing in the bottom of the ladder until it supports the weight of the roof top tent. If the angle of the ladder is between 70° and 75°, the adjustment is complete.

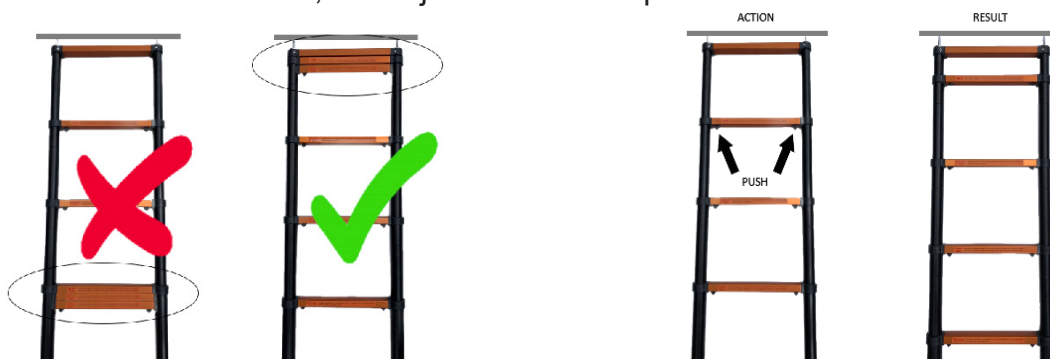

If further shortening is required press the second set of locking buttons (third rung from the top). This will close the 85mm gap until rung 1 & 2 are now touching. Swing in the bottom of the ladder until it supports the weight of the roof top tent. If the angle of the ladder is between 70° and 75°, this adjustment is complete.

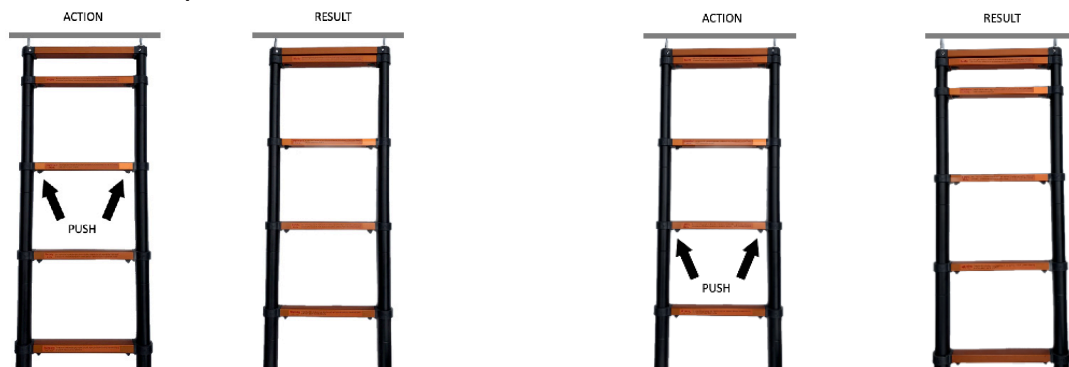

NOTE: When height adjusted, the ladder will only lock in the downward position.

If further adjustment is required, repeat the above steps by continuing the sequence by depressing the next set of locking buttons.

Opening & Set up

Once the Saber Super Fly is fixed securely to the vehicle's roof rack and the ladder is locked and angled correctly, climb the ladder, release the locks on either side of the tent and lift until the gas struts take over. Once open, lower the perimeter shock cord and hook this to both front corners of the baseboard. Locate the canopy stay poles and fit each of these into their brackets with the hook end facing outward. Flex each pole and insert the hook ends into the eyelets on the corners of the canopy. Unzip entry door and enter the roof top tent. The tent is now ready for use.

Closing & Storage

A moderate amount of additional bedding, such as a suitable sleeping bag, blanket, or pillow can be stored inside the tent for convenience

If excessive force is required to close the tent during pack-down, remove some bedding to avoid damage to tent components. Do not force the tent closed.

An internal bunji cord as well as an external perimeter shock cord is included with your Saber Super Fly hardshell roof top tent. These assist in reducing the canvas from billowing during pack up. Attach the internal bunji cord to either side of the Saber Super Fly via the fitted plastic loops inside the tent beside the windows. Exit the tent, remove the canopy tension poles and lift the perimeter shock cord halfway up the canvas ensuring it goes over the canopy canvas as well. The tent is now ready to close.

Tip: Leave the side windows open halfway open to allow internal air to escape while closing the tent.

As the Saber Super Fly is closing, tuck the canvas inside so none is caught between the sealing rubbers on the roof lid and baseboard. Engage the locks. Unhook the ladder, retract and stow in carry bag.

Caution: Avoid closing / storing tent wet. If conditions dictate that you do, open and dry out as soon as possible to avoid moisture damage.

2 Year Warranty

23ZERO will replace or repair any product at its discretion that is subject to faulty manufacturing or workmanship including materials.

Exclusions

The above warranty is limited to manufacturing and materials defects. Not including damage caused by misuse or abuse, wear and tear, condensation, extreme weather, accidents, incorrect set up, damage caused by mould, insects, animals or children. This also excludes broken poles and damage caused by a jammed, snagged zipper or excessive force applied to zipper causing failure.

Consumer rights

Our goods come with guarantees that cannot be excluded under Australian law. You are entitled to a replacement or refund for a major failure and for compensation for any other reasonably foreseeable loss or damage. You are also entitled to have goods repaired or replaced if the goods fail to be of acceptable quality and failure does not amount to a major failure.

* Due to our policy of continual product development, the specifications, colours and feature may vary.

Making a claim

To make a claim in relation to the above manufacturers warranty please ensure you retain your sales receipt of purchase. Please contact us stating the nature of your claim and we will be in touch with you shortly. If you require additional assistance, please phone 03 9547 4691 to discuss and arrange your claim. Product subject to warranty will be sent to 23ZERO Australia, 32b Eileen Rd. Clayton South, Victoria 3169. All freight costs associated with return of product for assessment is payable by consumer.

Mounting rail dimensions

The diagrams and dimensions below will assist in preparing roof racks and roof bars for fitment.

SIDE VIEW

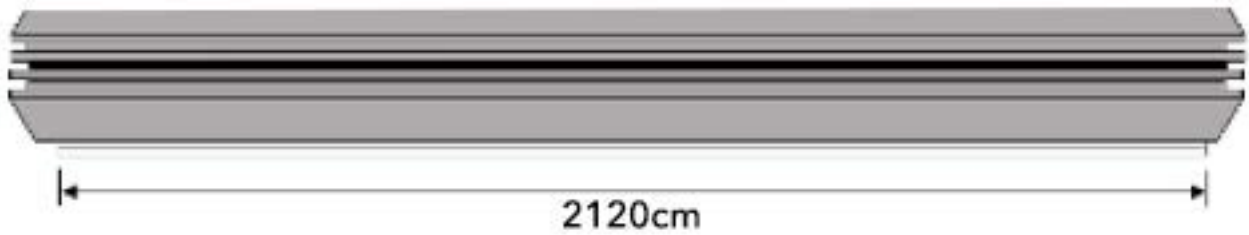

FRONT VIEW

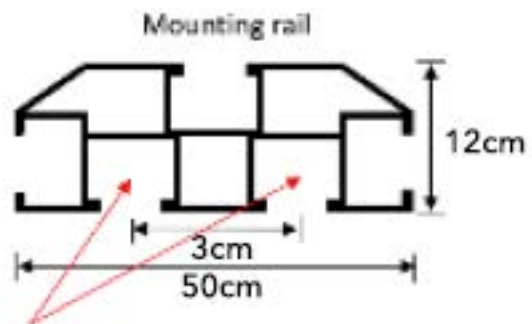
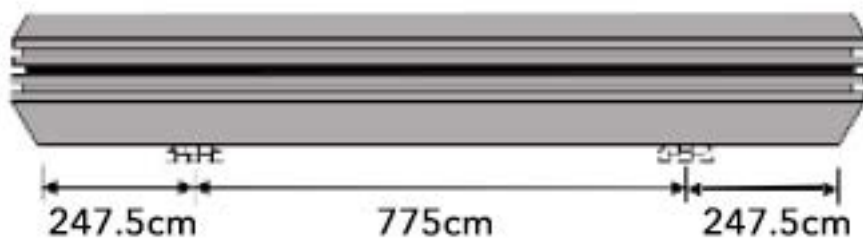

Slide mounting bolt in to either channel.



23ZERO AUSTRALIA
www.23zero.com.au
32B Eileen Rd Clayton South, VIC 3169
sales@23zero.com.au