



SABER SUPER LITE

USER MANUAL





Thank you for purchasing a 23 ZERO Roof Top Tent

Congratulations on the purchase of 23ZERO’s Saber Super Lite Hardshell Roof Top Tent. We strive to provide you with the ultimate camping experience. The Saber Super Lite Tent mounts directly to a roof rack or aftermarket roof bars. It opens and is fully setup in seconds. As well as our innovative LST fabric, this hardshell tent is made with durable materials and high-quality fabrics that provide excellent water and wind protection.

Most of the components have been pre-assembled with the exception of ladder brackets, awning stay pole brackets and roof bars. Depending on vehicle set up and choice of entry points, these components can be repositioned to suit.

Note: During set up and first use, some aluminium swarf may be present inside the roof top tent. We make every possible attempt to expel all aluminium swarf, however, with vibrations caused by logistics some residual may dislodge and reappear. It is advised to remove and clean these during first set up.

PLEASE READ ALL INSTRUCTIONS PRIOR TO INSTALLING

IMPORTANT

Before installing your 23Zero Roof Top Tent please ensure you are aware and understand the following:

- Your vehicle’s maximum roof load rating.
- Your roof rack’s maximum load rating including off-road capacity.

The maximum amount of weight you can safely add to a vehicle’s roof / cargo area differs according to make and type of vehicle including aftermarket additions such as roof racks / bars.

Note: Roof rack off-road limits are immensely different to normal road use load ratings. If in doubt, please contact your vehicle manufacturer and roof rack manufacturer / supplier for specified loading capacity of your vehicle and roof rack.

Not all factory roof racks or aftermarket roof bars can safely accommodate roof top tent models. The responsibility of fitting this roof top tent to rated roof racks or roof bars lays with the purchaser.

CONTENTS

Safety & Warnings	-----	2
Hardware & Accessories	-----	3
Latch Adjustment	-----	4
Fitting to roof-rack	-----	5
Roof Bars	-----	6
Ladder adjustment	-----	7
Opening & Set up	-----	8
Closing & Storage	-----	9
Warranty	-----	10

Safety & Warnings

Improper installation or use of the Saber Super Lite roof top tent may result in serious injury or death. Follow these installation instructions carefully to ensure proper installation to vehicle and safe use of the roof top tent.

Note: Alterations and / or inclusions such as roof racks and roof top tents applied to the vehicle roof may affect vehicle handling and characteristics.

The manufacturer (23ZERO) disclaims all responsibility in case of accidents and / or damage due to installation of a roof top tent to an underrated roof rack, improper use, improper maintenance or checking the tightness of the brackets regarding the installation of the roof rack system.

Inspections: Roof top tents have many moving parts, so maintenance checks are always advised. During trips regularly check that all nuts and bolts attaching the roof top tent to the vehicle as well as hinges and locks are tight and in good repair.

Ladder: For your safety and protection, ensure correct placement and angle of ladder. Recommended ladder placement is a 4:1 ratio or approx. 75°.

Ladder height may need to be adjusted depending on vehicle height, see “Ladder Adjustment”

DO NOT CLIMB ON LADDER UNTIL CORRECT ANGLE IS ACHIEVED

23Zero - The wholesaler / manufacturer shall not be liable for special, indirect incidental or consequential damages.

 **SAFETY WARNING** 
KEEP ALL FLAME AND HEAT SOURCES AWAY FROM THE TENT MATERIALS.
UNDER NO CIRCUMSTANCE SHOULD ANY NAKED FLAME SOURCES OR HEATING DEVICES
BE USED INSIDE OR NEAR THE TENT.
KEEP CAMP FIRES WELL AWAY FROM TENT.
KEEP A LOOK OUT FOR ANY AIRBORNE BURNING EMBERS THAT MAY COME INTO
CONTACT WITH THE TENT.
KEEP A FIRE EXTINGUISHER OR WATER BUCKET NEARBY.
DO NOT SMOKE WITHIN THE TENT.
DO NOT OPERATE ANY DEVICE WHICH BURNS FUEL INSIDE OF THE TENT.
KEEP EXIT CLEAR.

Hardware & Accessories

The Saber Super Lite Hardshell roof top tent includes a mounting kit with everything required to mount the roof top tent to most roof racks.

<p>M8 bolts, nuts & washers x 8</p> 	<p>Aluminium slide plate x 8</p> 
<p>Mounting saddles x 4</p> 	<p>Tools</p> 
<p>Light switch / dimmer x 1</p> 	<p>Mounting rail end cap x 4</p> 
<p>Shoe pockets x 1</p> 	

Note: Some platform style roof racks have platforms which are wider than the supplied mounting plate. 23ZERO have wider mounting plates available for this scenario.

Please visit www.23zero.com.au.

Important : Location of Saber Super Lite Lock Latches

For transportation purposes, the Saber Super Lite tent may be assembled with lock latches located at the front and rear profiles of the tent.

It is highly recommended that all four lock latches be repositioned to the outer sides, as indicated in the diagram below, to ensure a secure weather seal.



Fitting to roof rack

Recommended and efficient installation of the Saber Super Lite.

The Saber Super Lite is designed to be attached directly to a full-length platform-style rack or flat rack. For proper stability, the tent rails should be supported by planks or multiple cross members along the rack.

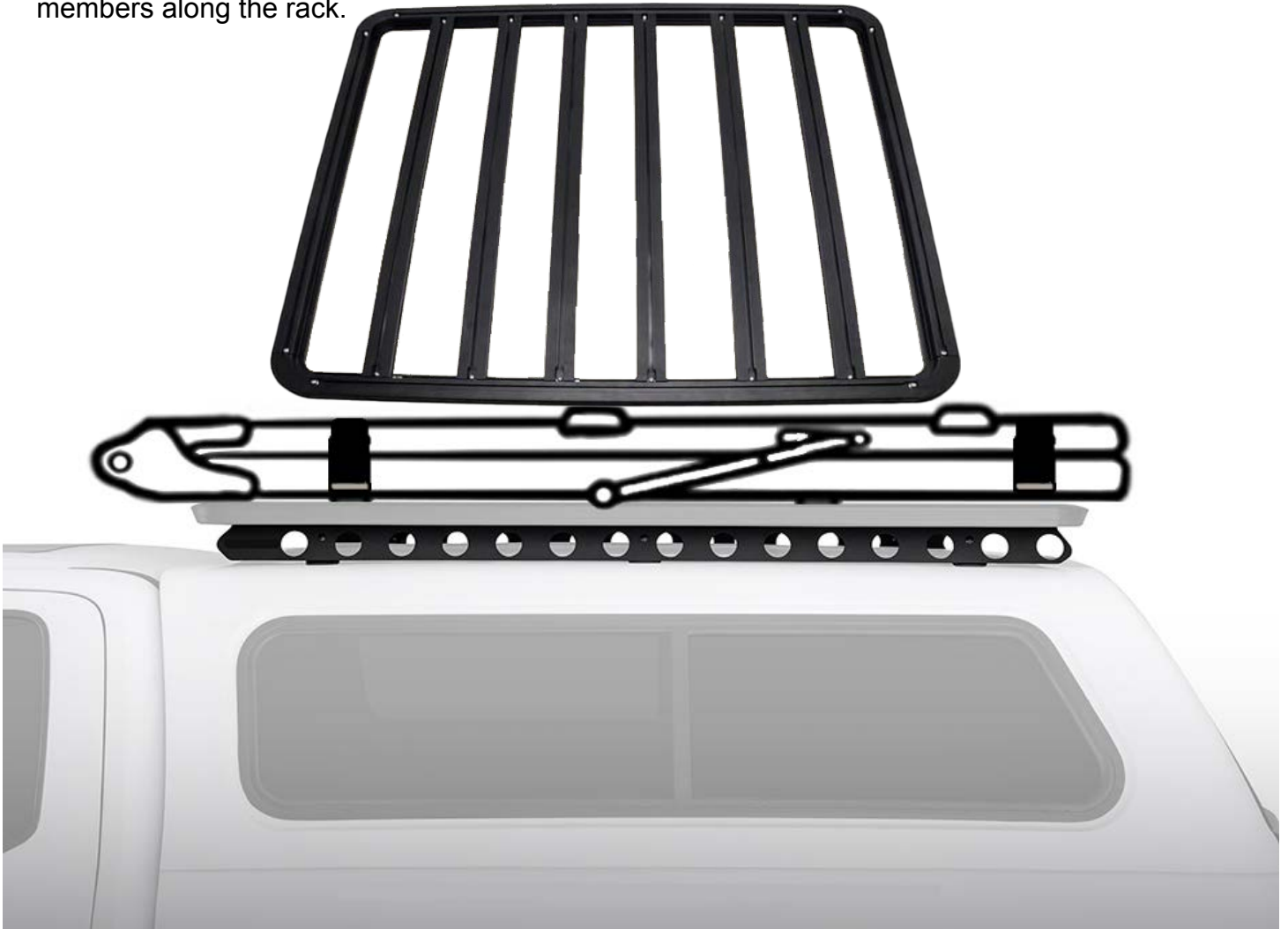

ENSURE TENT IS CLOSED AND OVER THE CENTRE LATCHES ARE FULLY SECURED DURING FITMENT

Proper Positioning of Over-Centre Lock Latches

For handling and transportation purposes, the over-center lock on the Saber Super Lite may need to be repositioned as shown in the diagram above to ensure a proper seal. If the tent is unpacked with the latches in a different position, please adjust them according to the diagram.

Secure the four corners using the provided 8 x M8 bolts, 8 slide plates, and 4 mounting saddles. Lift the roof top tent onto the vehicle's roof rack, making sure that at least four individuals are involved in the lifting process.

Insert the 8 x M8 bolts into the 8 slide plates and slide each into the bottom mounting rail. Position them so that there are two sets of bolts in each corner of the tent. Lift or tilt the roof top tent to facilitate the inner bolts crossing over onto the inside of the roof bars. Please refer to the picture below for visual guidance. Note that in this process, the mounting plate is replaced by the mounting saddle.

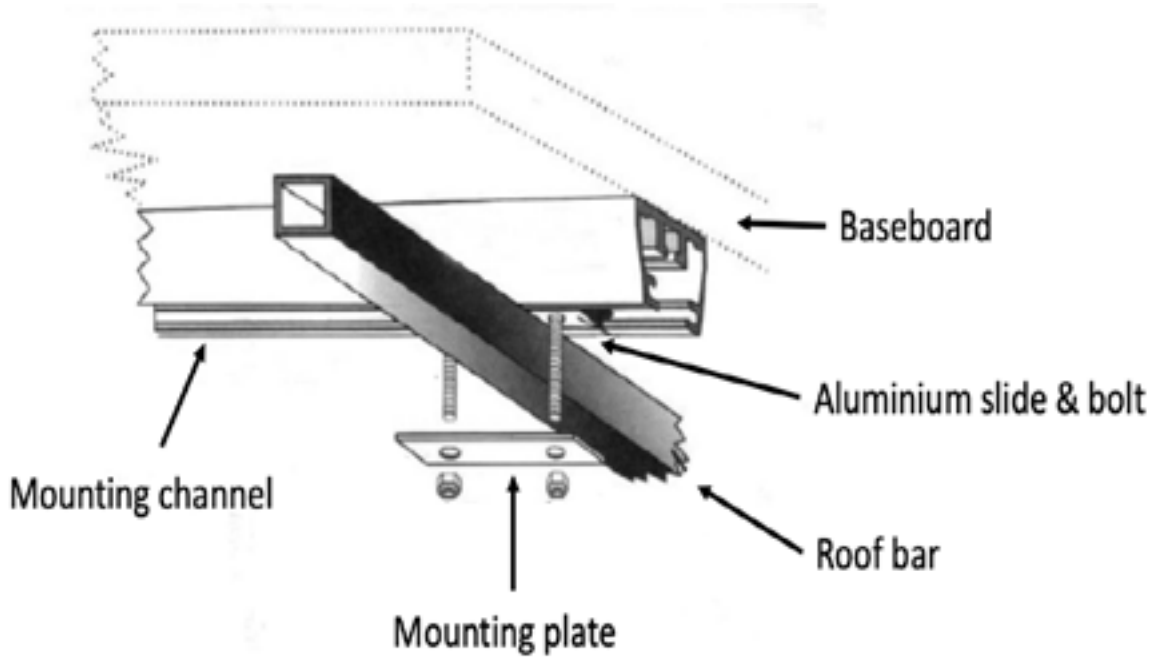

Inspect the position of the roof top tent to ensure it will open unobstructed in the desired orientation.

Note: It is recommended that the rear of the tent aligns flush with the back of the vehicle to ensure the correct ladder angle.

Place a mounting saddle under each roof bar while aligning the bolts. Insert washers and hand-tighten Nylock nuts. Repeat this process for all four corners. Double-check the tent's position as desired and securely tighten all nuts using a 13mm spanner. Insert end caps into the ends of the mounting rails; this may require gentle taps from a hammer.

Periodic inspections: Roof top tents have various moving parts, so regular maintenance checks are advisable. During trips, routinely inspect and ensure that all the above fixings are torqued and in good condition.

Roof bars



Note: The roof bars supplied with the Saber Super Lite roof top tent are not designed to carry significant loads. A maximum of 10kg can be carried on top of the Saber Super Lite providing this weight is spread evenly amongst the 2 bars.

When adding additional weight to the top of the Saber Super Lite consideration must be given to the overall weight rating capacity of your vehicle's roof and roof rack.

Please ensure you are aware and understand the following:

- Your vehicle's maximum roof load rating.
- Your roof rack's maximum load rating including off-road capacity.

The maximum amount of weight you can safely add to a vehicle's roof / cargo area differs according to make and type of vehicle including aftermarket additions such as roof racks / bars.

Important: Before each trip please check that all roof bar and bracket fixings are tight and in good order before adding load.

Ladder adjustment

For your safety and protection, ensure correct placement and angle of ladder. See diagrams below. Recommended ladder placement is a 4:1 ratio or approx. 70° to 75°.

NOTE: Under no circumstances should anyone be inside the roof top tent if the ladder is not locked and secured at the correct angle.



The ladder may need to be adjusted to achieve the correct angle depending on the height of your setup. If shortening is required, the adjustment must be done from the top.

Ensure the ladder is fully extended and all rungs are locked in place. Press the first set of locking buttons (second rung from the top) and allow the ladder to compress until a gap of approx. 85mm is achieved between rung 1 & 2.

Note: The ladder will only lock in the downward position.

Swing in the bottom of the ladder until it supports the weight of the roof top tent. If the angle of the ladder is between 70° and 75°, the adjustment is complete.

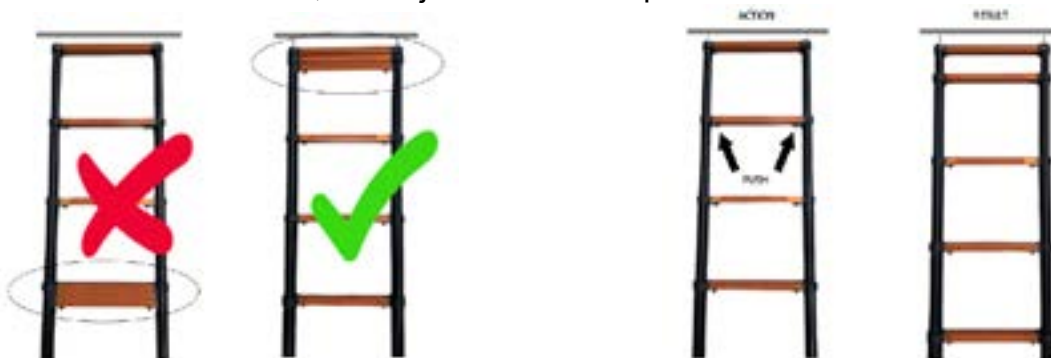

If further shortening is required press the second set of locking buttons (third rung from the top). This will close the 85mm gap until rung 1 & 2 are now touching. Swing in the bottom of the ladder until it supports the weight of the roof top tent. If the angle of the ladder is between 70° and 75°, this adjustment is complete.

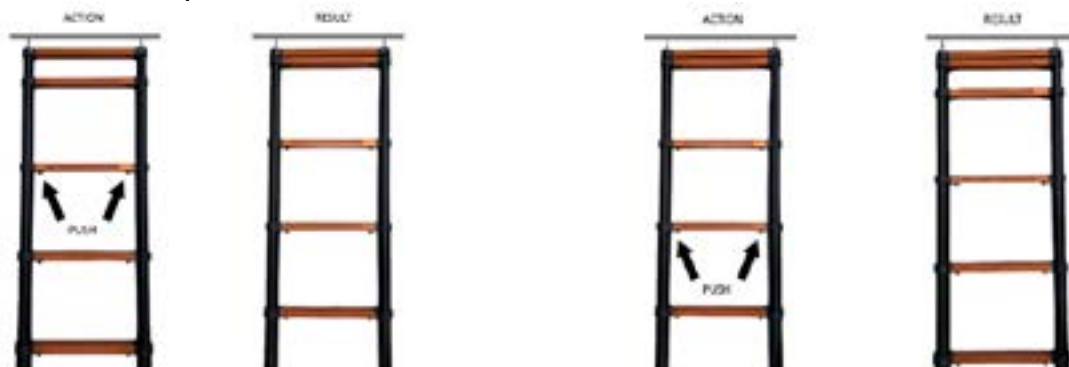

NOTE: When height adjusted, the ladder will only lock in the downward position.

If further adjustment is required, repeat the above steps by continuing the sequence by depressing the next set of locking buttons.

Opening & Set up

Once the Saber Super Lite is fixed securely to the vehicle's roof rack and the ladder is locked and angled correctly, climb the ladder, release the locks front and rear of tent and lift until the gas struts take over. Once open, lower the perimeter shock cord and hook this to both front corners of the baseboard. Unzip entry door and enter the roof top tent. The tent is now ready for use.

Closing & Storage

Sleeping bags, blankets or additional bedding including mattress toppers can not be stowed inside the Saber Super Lite due to its low profile design

An external perimeter shock cord is included with your Saber Super Lite hardshell roof top tent. These assist in reducing the canvas from billowing during pack up. Exit the tent, lift the perimeter shock cord halfway up the canvas ensuring it goes over the canopy canvas as well. The tent is now ready to close.

Tip: Leave the side windows open halfway open to allow internal air to escape while closing the tent.

As the Saber Super Lite is closing, tuck the canvas inside so none is caught between the sealing rubbers on the roof lid and baseboard. Engage the locks. Unhook the ladder, retract and stow in carry bag.

Caution: Avoid closing / storing tent wet. If conditions dictate that you do, open and dry out as soon as possible to avoid moisture damage.

2 Year Warranty

23ZERO will replace or repair any product at its discretion that is subject to faulty manufacturing or workmanship including materials.

Exclusions

The above warranty is limited to manufacturing and materials defects. Not including damage caused by misuse or abuse, wear and tear, condensation, extreme weather, accidents, incorrect set up, damage caused by mould, insects, animals or children. This also excludes broken poles and damage caused by a jammed, snagged zipper or excessive force applied to zipper causing failure.

Consumer rights

Our goods come with guarantees that cannot be excluded under Australian law. You are entitled to a replacement or refund for a major failure and for compensation for any other reasonably foreseeable loss or damage. You are also entitled to have goods repaired or replaced if the goods fail to be of acceptable quality and failure does not amount to a major failure.

* Due to our policy of continual product development, the specifications, colours and features may vary.

Making a claim

To make a claim in relation to the above manufacturers warranty please ensure you retain your sales receipt of purchase. Please contact us stating the nature of your claim and we will be in touch with you shortly. If you require additional assistance, please phone 03 9547 4691 to discuss and arrange your claim. Product subject to warranty will be sent to 23ZERO Australia, 32b Eileen Rd. Clayton South, Victoria 3169. All freight costs associated with return of product for assessment is payable by consumer.



23ZERO AUSTRALIA
www.23zero.com.au
32B Eileen Rd Clayton South, VIC 3169
sales@23zero.com.au